

--	--	--	--	--	--	--	--	--	--	--	--	--	--	--	--	--	--	--	--

NOIDA INSTITUTE OF ENGINEERING AND TECHNOLOGY, GREATER NOIDA

(An Autonomous Institute Affiliated to AKTU, Lucknow)

B.Tech

SEM: V - CARRY OVER THEORY EXAMINATION - AUGUST 2023

Subject: Control System

Time: 3 Hours

Max. Marks: 100

General Instructions:

IMP: Verify that you have received the question paper with the correct course, code, branch etc.

1. This Question paper comprises of **three Sections -A, B, & C**. It consists of Multiple Choice Questions (MCQ's) & Subjective type questions.
2. Maximum marks for each question are indicated on right -hand side of each question.
3. Illustrate your answers with neat sketches wherever necessary.
4. Assume suitable data if necessary.
5. Preferably, write the answers in sequential order.
6. No sheet should be left blank. Any written material after a blank sheet will not be evaluated/checked.

SECTION A

20

1. Attempt all parts:-

- | | | |
|------|--|---|
| 1-a. | In an open loop system. (CO1) | 1 |
| | (a) Output controls the input signal | |
| | (b) Output has no control over input signal | |
| | (c) Some other variable control the input signal | |
| | (d) Neither output nor any other variable has any effect on input | |
| 1-b. | If the poles of a system lie on the imaginary axis, the system will be (CO1) | 1 |
| | (a) Stable | |
| | (b) Conditionally stable | |
| | (c) Marginally stable | |
| | (d) Unstable | |
| 1-c. | The time required for step response to decrease and stay within the specified band of final value is called. (CO2) | 1 |
| | (a) Delay time | |
| | (b) Peak time | |

- (c) Rise time
(d) Settling time
- 1-d. The system with the open loop transfer function $1/s(1+s)$ is. (CO2) 1
- (a) Type 2 and order 1
(b) Type 2 and order 0
(c) Type 0 and order 1
(d) Type 1 and order 2
- 1-e. If the minimum phase system is to be stable, then. (CO2) 1
- (a) Both gain margin and phase margin are negative.
(b) Both gain margin and phase margin are positive.
(c) Gain margin is positive and phase margin is negative.
(d) None of these
- 1-f. For a type 1 system, the intersection of the initial slope of the bode with 0 dB axis gives.. (CO3) 1
- (a) Steady-state error
(b) Error constant
(c) Phase margin
(d) Crossover frequency
- 1-g. $dx(t)/dt = Ax(t) + Bu(t)$ is called the . (CO4) 1
- (a) Output Equation
(b) State equation
(c) State transition equation
(d) System equation
- 1-h. Which among the following is a unique model of a system? (CO4) 1
- (a) Transfer function
(b) State variable
(c) Block Diagram
(d) SFG
- 1-i. A discrete-data system is described by... (CO5) 1
- (a) Exponential equations
(b) difference or discrete state equations
(c) differential equations
(d) None of the above

- 1-j. The ramp error constant for the type 1 system of the discrete data control system will be.. (CO5) 1
- (a) K
 - (b) 0
 - (c) 1
 - (d) infinity

2. Attempt all parts:-

- 2.a. What is a time-invariant System? (CO1) 2
- 2.b. Draw the block diagram of PID controller. (CO2) 2
- 2.c. State angle and magnitude criteria in Root-locus.(CO3) 2
- 2.d. Explain the limitations of classical theory of system analysis. (CO4) 2
- 2.e. What is uniform quantization? (CO5) 2

SECTION B

30

3. Answer any five of the following:-

- 3-a. What do you mean by analogous system? Explain Force-Voltage analogy with suitable example. (CO1) 6
- 3-b. What is feedback? Briefly Explain the effects of feedback on control system. (CO1) 6
- 3-c. Derive the expressions and draw the response of first order system for unit ramp input with neat and clean diagram. (CO2) 6
- 3-d. Assume any second order system transfer function, calculate all error coefficient and steady state error for a unit step input. (CO2) 6
- 3.e. Sketch the Nyquist plot for the open loop transfer function of $G(s)H(s)=10/(s+2)(s+2)$. Also, determine the stability of the closed loop system. (CO3) 6
- 3.f. Write a short note on State, state variable, state space and state vector. (CO4) 6
- 3.g. Obtain the z-transform of function whose Laplace transform is given by $F(s) = 1/(s+a)$. (CO5) 6

SECTION C

50

4. Answer any one of the following:-

- 4-a. Find the transfer function of the following block diagrams using BDR. (CO1) 10

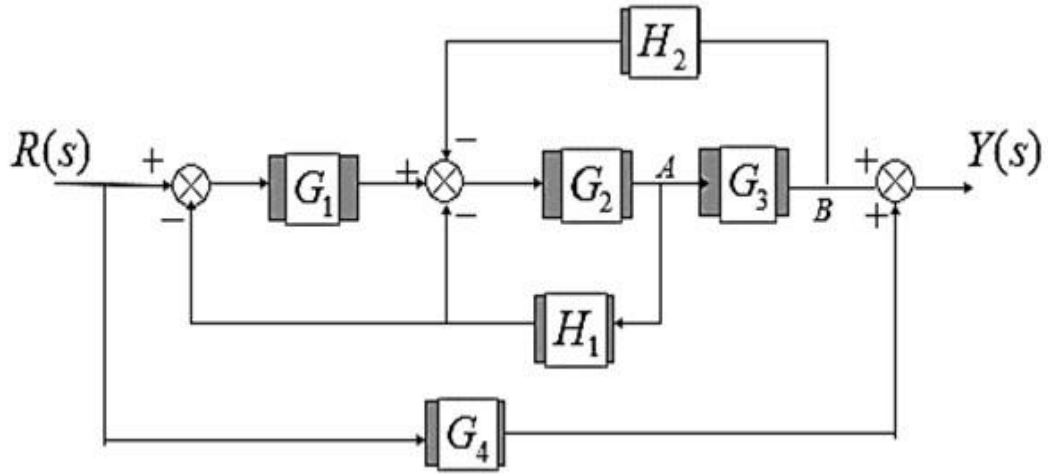

- 4-b. Find the transfer function of given SFG using Mason's Gain formula. (CO1) 10

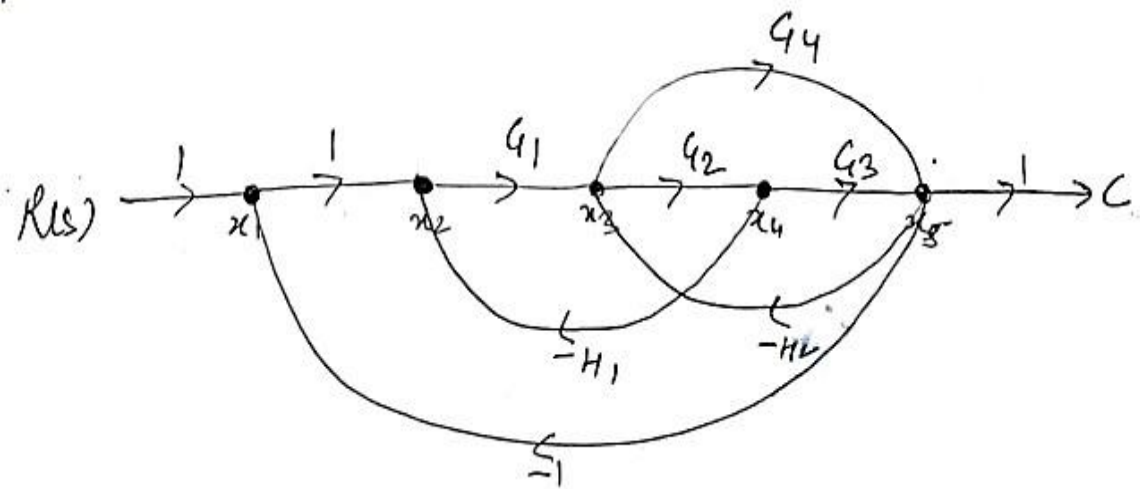

5. Answer any one of the following:-

- 5-a. Derive the expression for rise time, maximum overshoot & peak time of second order system subjected to unit step input. (CO2) 10
- 5-b. The open loop transfer function of unity feedback system is $G(s) = 25/s(s+5)$ 10
 .Find (i) Natural frequency of oscillation (ii) damping frequency of oscillation (iii) Damping ratio (iv) Maximum overshoot of unit step input. (CO2)

6. Answer any one of the following:-

- 6-a. What is the necessary and sufficient condition for the RH criterion? Determine the stability of a control system whose overall transfer function is given below. (CO3) 10

$$\frac{C(s)}{R(s)} = \frac{2s + 5}{s^5 + 1.5s^4 + 2s^3 + 4s^2 + 5s + 10}$$

- 6-b. Design the bode plot for the system whose open loop transfer function is given below and determine (a) GM (b) PM (c) System stability.(CO3) 10

$$G(s) = \frac{4}{s(1+0.5s)(1+0.08s)}$$

7. Answer any one of the following:-

- 7-a. Determine the state-space model for the electrical circuit. (CO4) 10

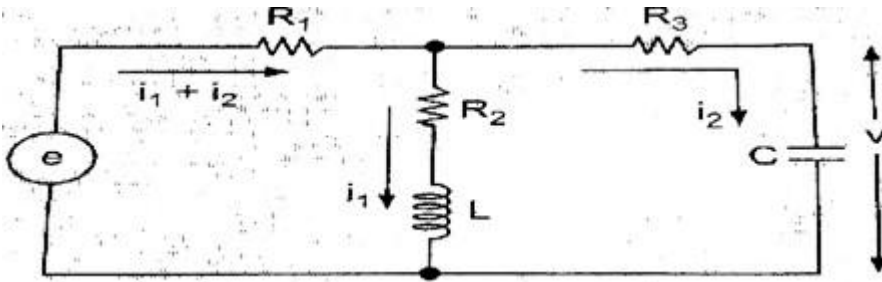

- 7-b. Apply the cascade decomposition method to obtain the state space model of the transfer function given as. (CO4) 10

$$G(s) = \frac{s^2 + 6s + 8}{(s + 3)(s^2 + 2s + 5)}$$

8. Answer any one of the following:-

- 8-a. Describe the Sample and Hold Device with circuit diagram and waveform in detail. (CO5) 10
- 8-b. Discuss the Stability of the discrete data system including conditions of Stable, Unstable, or Marginally Stable. Also, explain the bilinear transformation method to check system stability. (CO5) 10